

# MAFI 91274

Solar

## Roof Tile Heavy

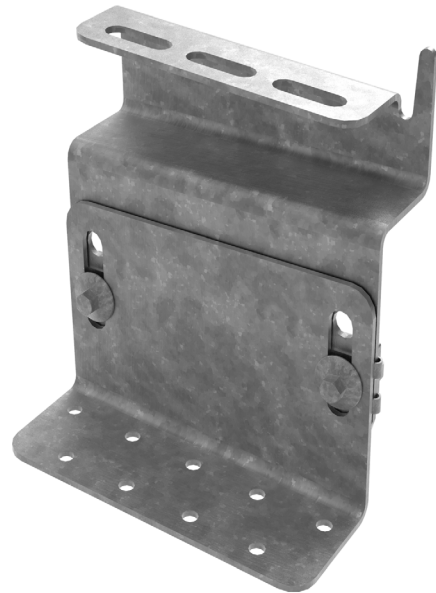
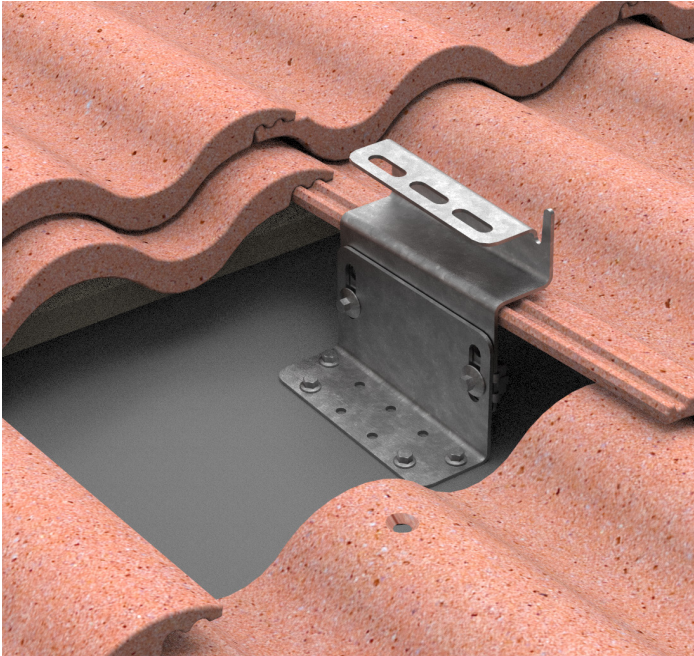

### About the Product

The Roof Tile Heavy is an adjustable bracket designed to be fastened to the boarded subroof, which enables the mounting of solar panels on curved roof tiles. The parts are sold separately and are mounted together using 2x 9834 Flange Bolt M8x20 and 2x 9839 Speed Clip with the 9843 HEX Locker 8 mm. The Roof Tile Heavy is made from Magnelis®.

### Flexibility

The Solar Rail can be installed both vertically and horizontally. When installed horizontally, the bracket has a versatile equipment hole pattern for matching the clamping zone of the panel and a stop hook to temporarily support the Solar Rail before mounting. The recognizable MAFI hole pattern enables installations together with Roof Tile Bracket on the same roof.

### How to Order

To order, please contact MAFI quoting article number:

**MAFI 912741**

**MAFI 912742**

Please visit <https://www.mafigroup.com/how-to-order/> for regional contact information.



**MAFI 912741**



**MAFI 912742**

## Measurements in millimeters

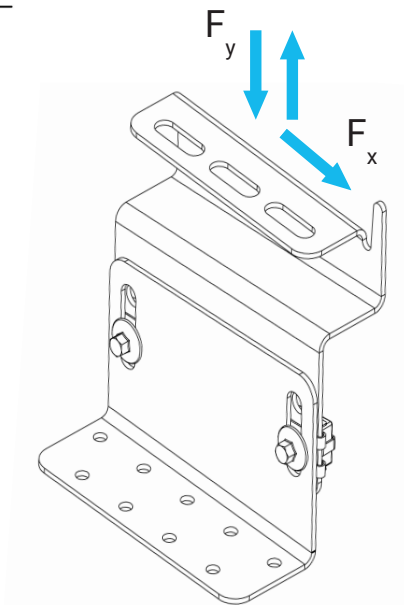
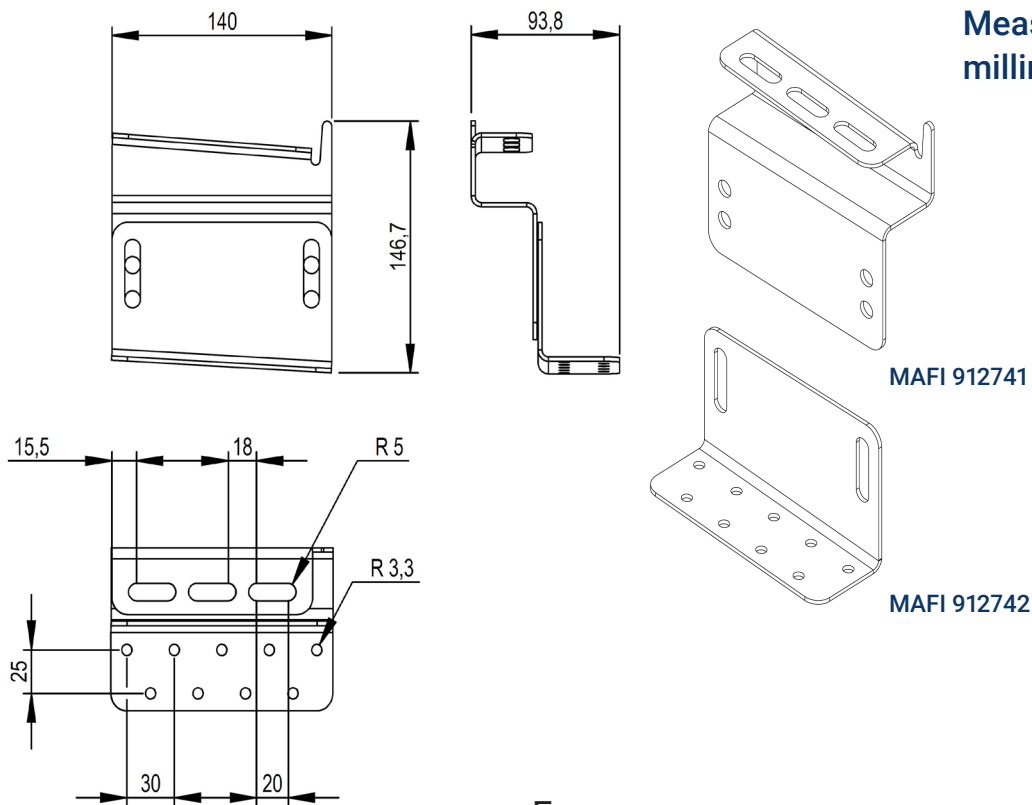

## Info

Ultimate design load

$F_{y \text{ down}}$  max: 1500 N

$F_{y \text{ up}}$  max: 1500 N

$F_x$  max: 1500 N

## Parts list

Part	Material	Quantity	Weight (g)
Roof Tile Heavy Top	S550GD ZM310	1	467
Roof Tile Heavy Bot	S550GD ZM310	1	334
			Total: 801

## Compatible products

9834: Flange Bolt M8x20

9839: Speed Clip

9730: Screw for Roof Tile Bracket 5.0x40

9843: HEX Locker 8 mm



912741



912742